





**DETAIL SPECIFICATION**REF.: **RAD-DET-ATCH-018****Date:**
September 23rd 2020**ED/REV:**
1 / A**PAGE:**
1 / 13

Titre / Title

**RF COAXIAL ATTENUATORS
DC – 50 GHz****DETAIL SPECIFICATION**

Rédigé par / Written by	Responsabilité / Responsibility	Date	Signature
S. POIZAT	Space Project Manager	23/09/2020	
Vérifié par / Verified by			
V. EUDELIN	Space B. U. Manager	23/09/2020	
Approuvée par / Approved by			
E. ALVES	Space Quality Manager	23/09/2020	

	DETAIL SPECIFICATION		
	REF.: RAD-DET-ATCH-018		
	Date: September 23 rd 2020	ED/REV: 1 / A	PAGE: 2 / 13

DOCUMENTATION CHANGE NOTICE

REVISION OR ISSUE	DATE	CHANGE
1 -	08/04/2020	Initial issue
1 A	23/09/2020	0.5dB variants available upon request



	DETAIL SPECIFICATION		
	REF.: RAD-DET-ATCH-018		
	Date: September 23 rd 2020	ED/REV: 1 / A	PAGE: 3/ 13

TABLE OF CONTENTS

1.	Scope	4
2.	Applicable document	4
3.	Type variant	5
4.	Maximum ratings	6
5.	Electrical measurements	7
6.	Connectors repeatability:	7
7.	Operating life	7
7.1.	Parameter drift values	7
7.2.	Conditions for operating life	7
8.	Mechanical dimension	9
8.1.	Dimension for variants 101 to 122	9
8.2.	Interchangeability for 2.4mm series	10
8.2.1.	2.4mm plug	10
8.2.2.	2.4mm jack	11

LIST OF TABLES AND FIGURES

Table 1:	<i>Type variants</i>	5
Table 2:	<i>Maximum ratings</i>	6
Table 3:	<i>Parameter drift values for Operating Life</i>	7
Table 4:	<i>Conditions for Operating Life testing</i>	7
Table 5:	<i>Radiall Part Number</i>	12
Table 6:	<i>Measurements and inspections on completion of environment and endurance tests</i>	12
FIGURE 1	<i>– Temperature derating</i>	6
FIGURE 2	<i>– Circuit for electrical measurement</i>	8

	DETAIL SPECIFICATION		
	REF.: RAD-DET-ATCH-018		
	Date: September 23 rd 2020	ED/REV: 1 / A	PAGE: 4 / 13

1. SCOPE

This Detail Technical Sheet details the ratings and electrical characteristics for RF Attenuators, Coaxial 0-20 dB, 0 - 50 GHz, 2.4mm series

2. APPLICABLE DOCUMENT

The following documents shall be read in conjunction with this specification:

RAD-GEN-ATCH-002: General Specification: Attenuators and Loads RF Fixed Coaxial

	DETAIL SPECIFICATION		
	REF.: RAD-DET-ATCH-018		
	Date: September 23 rd 2020	ED/REV: 1 / A	PAGE: 5 / 13

3. TYPE VARIANT

Variants of the basic type covered by the relevant Generic Specification are given Table 1.

Table 1: Type variants

Var. N°	Attenuation	Maximum Input Power W	Attenuation tolerance Vs frequency		Flatness	VSWR
	dB		0 < F ≤ 26.5 GHz (dB)	26.5 < F ≤ 50GHz (dB)	dB	
201	0 (DC shunt)	5	0 / -0.7	0 / -0.7	F ≤ 20 GHz 0.15 dB / 1GHz	0 < F ≤ 26.5GHz < 1.3
202*	0.5	5	±0.4	±0.7		
203	1	3.5	±0.4	±0.7		
204*	1.5	2.75	±0.4	±0.7		
205	2	2.75	±0.4	±0.7		
206*	2.5	2	±0.4	±0.7		
207	3	1.5	±0.4	±0.7		
208*	3.5	1.5	±0.4	±0.7		
209	4	1.5	±0.4	±0.7		
210*	4.5	1.5	±0.4	±0.7		
211	5	1.25	±0.4	±0.7	F > 20 GHz 0.2 dB / 1GHz	26.5 < F < 40GHz < 1.5
212*	5.5	1.25	±0.4	±0.7		
213	6	1.25	±0.4	±0.7		
214*	6.5	1.25	±0.4	±0.7		
215	7	1	±0.4	±0.7		
216*	7.5	1	±0.4	±0.7		
217	8	1	±0.4	±0.7		
218*	8.5	1	±0.4	±0.7		
219	9	1	±0.4	±0.7		
220*	9.5	1	±0.4	±0.7		
221	10	1	±0.4	±0.7	40 < F < 50GHz < 1.65	
222	20	0.5	±0.5	±1		

* Variants available upon request

	DETAIL SPECIFICATION		
	REF.: RAD-DET-ATCH-018		
	Date: September 23 rd 2020	ED/REV: 1 / A	PAGE: 6 / 13

4. MAXIMUM RATINGS

Maximum Ratings of the basic type covered by the relevant Generic Specification are given Table 2.

Table 2: Maximum ratings

N°	Characteristics	Symbol	Maximum Rating		Unit	Comment
			Min	Max		
1	RF Power dissipation ⁽¹⁾	P	-	1	W ⁽²⁾	(0.5W for variant 222)
2	Peak Power (at 25°C) ⁽³⁾	Pp	-	50	W	-
3	Operating Temperature Range	T _{op}	-55	+125	°C	-
4	Storage Temperature Range	T _{stg}	-55	+125	°C	-
5	Frequency Range	F	0	50	GHz	-
6	Impedance	Z	47.5	52.5	Ω	-
7	DC impedance		3	10	KΩ	between coaxial line and body
8	RF Leakage	E	-85	-	dBi	-
9	Coupling Nut Torque	Tq	80	120	N.cm	-
10	Glitches		0	0.05	dB	

- NOTES:**
- (1) See Table 1 for RF input Power value vs attenuation
 - (2) See Figure 1.
 - (3) Duration 1µs, cyclic rate 1ms

FIGURE 1 – Temperature derating

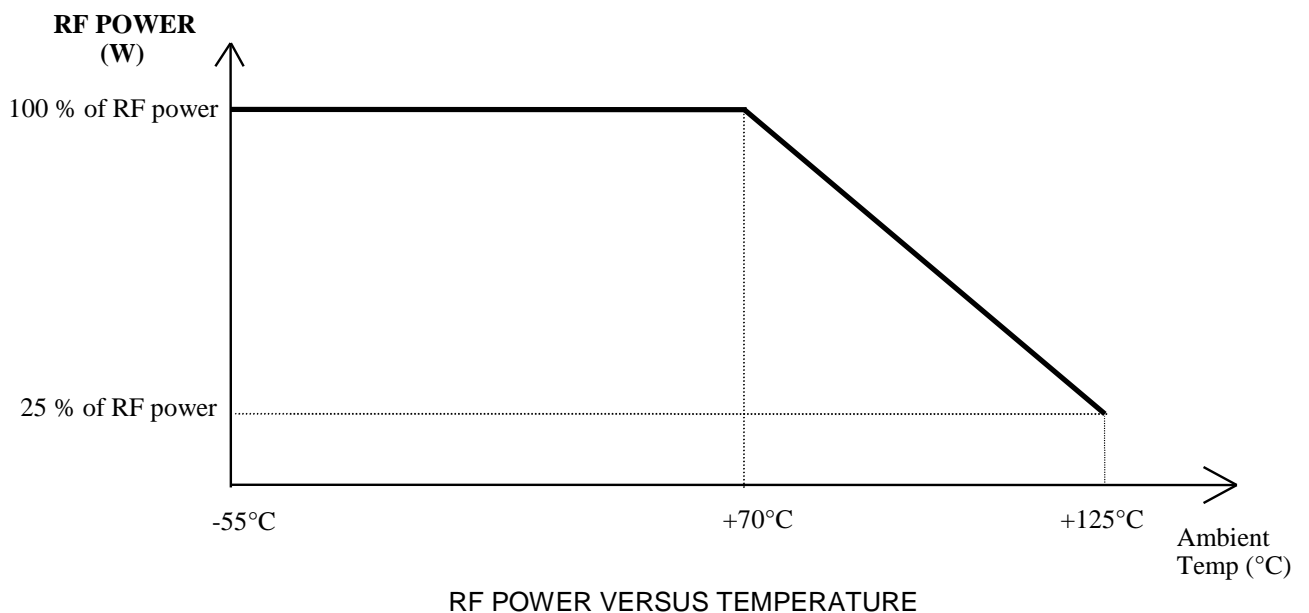

	DETAIL SPECIFICATION		
	REF.: RAD-DET-ATCH-018		
	Date: September 23 rd 2020	ED/REV: 1 / A	PAGE: 7/ 13

5. ELECTRICAL MEASUREMENTS

The parameters to be measured at room temperature are scheduled in Table 1. Unless otherwise specified, the measurements shall be performed at $T_{amb} = +22 \pm 3$ °C.

The measurement shall be performed with five points of frequency:

10GHz – 20GHz – 30GHz – 40GHz - 50GHz

6. CONNECTORS REPEATABILITY:

The test shall be performed according to the following conditions:

- Attenuation shall be recorded at three points of frequency: 10GHz – 30GHz - 50GHz
- Ten complete engagements and separations shall be performed, both end separately
- Attenuators shall be rotated through the full 360° with an increment of approximately 36° for each engagement.
- Attenuation drift value: ± 0.05 dB
- Side thrust is not permitted during the test
- Cleaning of connectors or reshaping of contacts was not permitted during the sequence

7. OPERATING LIFE

7.1. PARAMETER DRIFT VALUES

The parameter drift values applicable to burn-in are specified in Table 3 of this specification. Unless otherwise stated, measurements shall be performed at $T_{amb} = +22 \pm 3$ °C. The parameter drift value (Δ) applicable to the parameters scheduled, shall not be exceeded. In addition to these drift value requirements for a given parameter, the appropriate limit value specified in Table 1 shall not be exceeded.

7.2. CONDITIONS FOR OPERATING LIFE

The condition for Operating life is given in Table 4. After test, a visual inspection shall be performed and no damage shall be appeared.

Table 3: Parameter drift values for Operating Life

N°	Characteristics	Symbol	Test condition	Limits	Unit
1	Attenuation Drift	Δ_{Att}	As per Table 1	± 0.10 or ± 1 ⁽¹⁾	dB %

NOTES: (1) Whichever is greater, % of nominal attenuation

Table 4: Conditions for Operating Life testing

N°	Characteristics	Symbol	Limits	Unit	Note
1	RF Power	P_{in}	See Table 1	W	
2	Frequency	F	DC ⁽¹⁾ or 10 or 18 10 or 18	GHz GHz	For attenuation ≥ 1 dB For attenuation < 1 dB
3	Ambient Temperature	T_{amb}	+70	°C	-

NOTES: (1) The response of the attenuation is flat over the frequency bandwidth.
The dissipated power at DC or in frequency is the same.

	DETAIL SPECIFICATION		
	REF.: RAD-DET-ATCH-018		
	Date: September 23 rd 2020	ED/REV: 1 / A	PAGE: 8 / 13

Test mounting for Operating life:

The DUT (attenuator under test) shall be mounted directly on the Hybrid coupler without SR cable between the coupler and the DUT.

FIGURE 2 – *Circuit for electrical measurement*

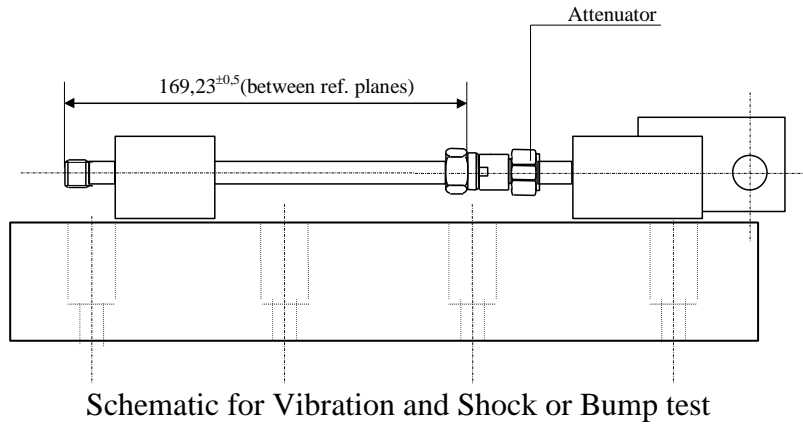

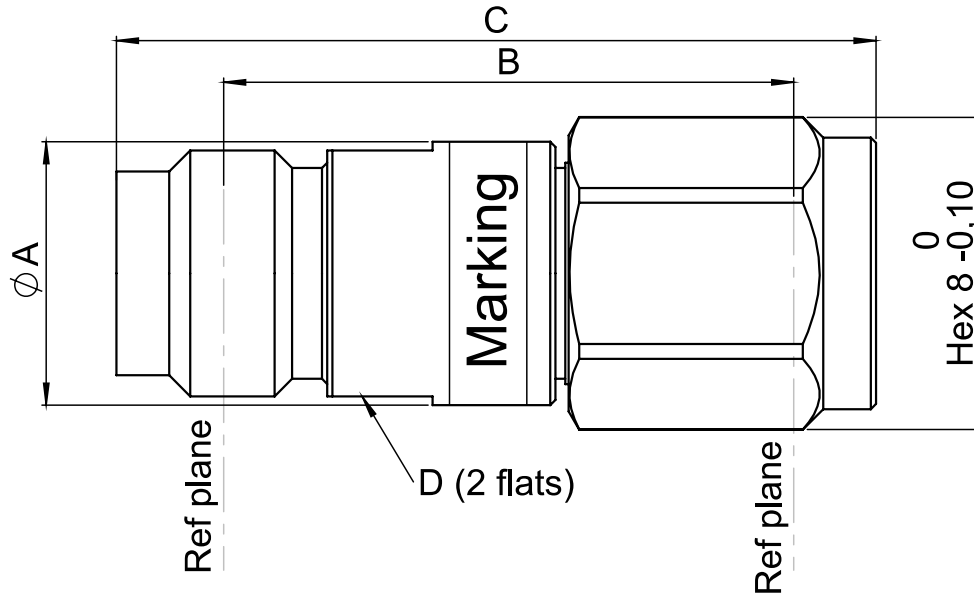
8. MECHANICAL DIMENSION
8.1. DIMENSION FOR VARIANTS 201 TO 222

SYMBOL / CHARACTERISTICS	PHYSICAL DIMENSION (mm)	
	Min	Max
∅ A	7	8
B	16	16.5
C	-	22
D	6.5	7.5

General tolerance: ± 0.5 mm
 Connectors: 2.4mm Male/Female per MIL STD 348A
 Weight: ≤ 7 grams

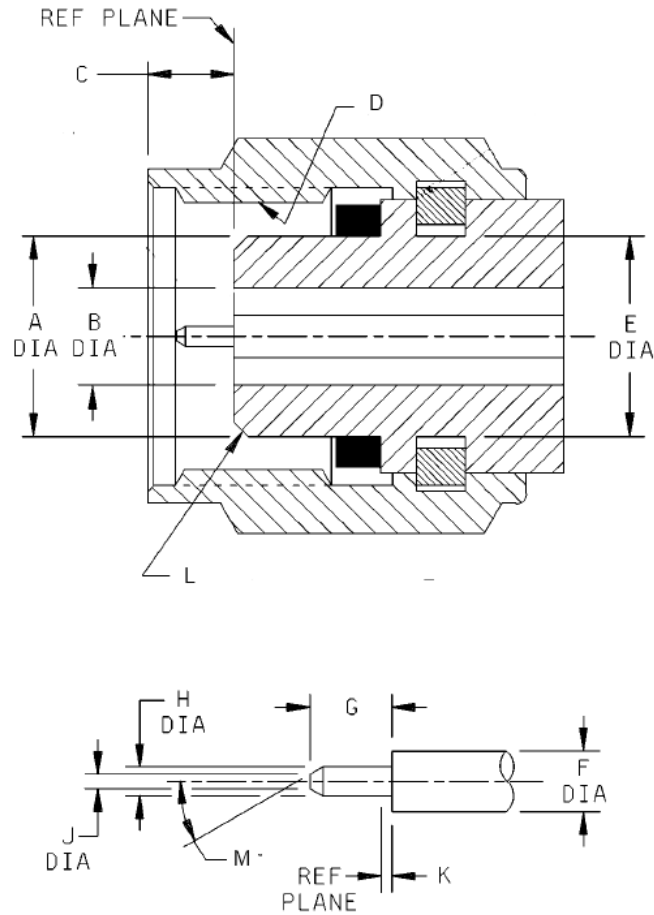
8.2. INTERCHANGEABILITY FOR 2.4MM SERIES
8.2.1. 2.4mm plug

Symbols	Dimension (mm)		Comment
	Min	Max	
ØA	4.725	4.75	
ØB	2.387	2.413	
C	1.85	2.45	
D	M7 x 0.75-6g		
ØE	4.75	4.85	
ØF	1.029	1.054	
G	1.34	1.45	
ØH	0.506	0.523	
ØJ	0.2	0.25	
K	0	0.08	
L	0.25 x 45°±2	0.35 x 45°±2	Chamfer
M	28	32	°

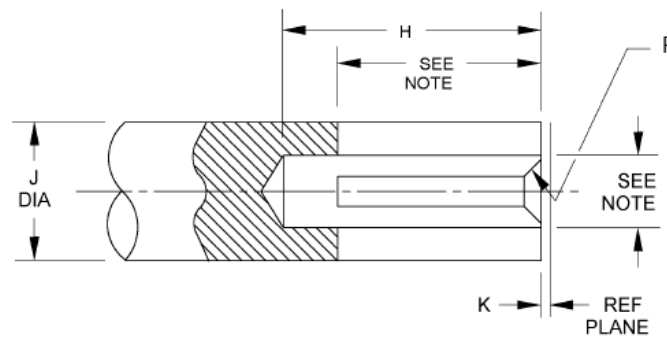
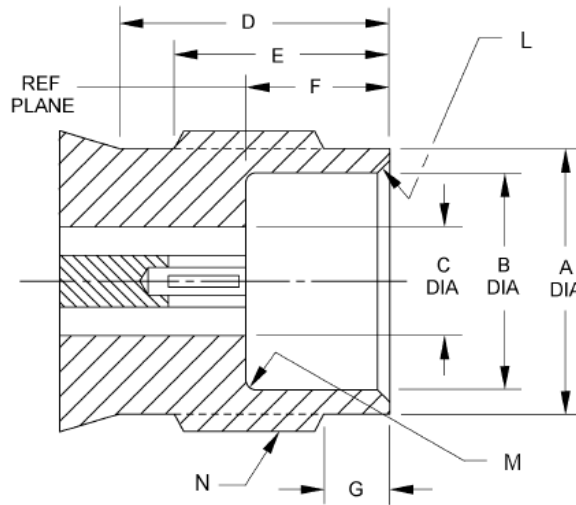
8.2.2. 2.4mm jack

Symbols	Dimension (mm)		Comment
	Min	Max	
ØA	5.79	5.89	
ØB	4.77	4.8	
ØC	2.387	2.413	
D	6	-	
E	4.8	5.06	
F	3	3.1	
G	1.37	1.63	
H	2.65	-	
ØJ	1.029	1.054	
K	0	0.08	
L	0.1 x 45°±2	0.2 x 45°±2	Chamfer
M	-	0.127	Radius
N	M7 x 0.75-6g		
P	0.1 x 30°±2	0.15 x 30°±2	Chamfer

Note: Shall meet the electrical and mechanical performance requirements when mated with a 2.4mm pin as specified in this specification



DETAIL SPECIFICATION

REF.: RAD-DET-ATCH-018

Date:
September 23rd 2020

ED/REV:
1 / A

PAGE:
12 / 13

Table 5: Radiall Part Number

Variant	Radiall Reference	Designation
201	R413N00660	Attenuator 2.4mm DC - 50GHz 0 dB (DC Shunt)
202*	R413N01660	Attenuator 2.4mm DC - 50GHz 0.5 dB
203	R413N02660	Attenuator 2.4mm DC - 50GHz 1 dB
204*	R413N03660	Attenuator 2.4mm DC - 50GHz 1.5 dB
205	R413N04660	Attenuator 2.4mm DC - 50GHz 2 dB
206*	R413N05660	Attenuator 2.4mm DC - 50GHz 2.5 dB
207	R413N06660	Attenuator 2.4mm DC - 50GHz 3 dB
208*	R413N07660	Attenuator 2.4mm DC - 50GHz 3.5 dB
209	R413N08660	Attenuator 2.4mm DC - 50GHz 4 dB
210*	R413N09660	Attenuator 2.4mm DC - 50GHz 4.5 dB
211	R413N10660	Attenuator 2.4mm DC - 50GHz 5 dB
212*	R413N11660	Attenuator 2.4mm DC - 50GHz 5.5 dB
213	R413N12660	Attenuator 2.4mm DC - 50GHz 6 dB
214*	R413N13660	Attenuator 2.4mm DC - 50GHz 6.5 dB
215	R413N14660	Attenuator 2.4mm DC - 50GHz 7 dB
216*	R413N15660	Attenuator 2.4mm DC - 50GHz 7.5 dB
217	R413N16660	Attenuator 2.4mm DC - 50GHz 8 dB
218*	R413N17660	Attenuator 2.4mm DC - 50GHz 8.5 dB
219	R413N18660	Attenuator 2.4mm DC - 50GHz 9 dB
220*	R413N19660	Attenuator 2.4mm DC - 50GHz 9.5 dB
221	R413N20660	Attenuator 2.4mm DC - 50GHz 10 dB
222	R413N40660	Attenuator 2.4mm DC - 50GHz 20 dB

* Variants available upon request

	DETAIL SPECIFICATION		
	REF.: RAD-DET-ATCH-018		
	Date: September 23 rd 2020	ED/REV: 1 / A	PAGE: 13 / 13

TABLE 6: Measurements and inspections on completion of environment and endurance tests

N°	Radiall Generic Spec. RAD-GEN-ATCH-002		Measurements and Inspections		Symbol	Limits		Unit
	Environmental and Endurance Test (1)	Test Method and Conditions	Identification	Conditions		Min	Max	
01	Vibration	Para. 13.2.6 of Generic specification and figure 2 of this specification	Initial measurements Attenuation During Last Cycle Intermittent contact Final measurement Visual Examination Attenuation drift	Table 1 >0.5ms No open or short circuits No damage Table 1	Att - - ΔAtt	Record values - - ±0.05 ±0.5		- - - dB or % (2)
02	Shock or Bump	Para 13.2.7 of Generic specification and figure 2 of this specification	Initial measurements Attenuation Final measurement Visual Examination Attenuation drift	Table 1 No damage Table 1	Att - ΔAtt	Record values - ±0.05 ±0.5		- - dB or % (2)
03	Rapid Change of Temperature	Para 13.2.8 of Generic specification	Initial measurements Attenuation Final measurement Visual Examination Attenuation drift	Table 1 After recovery time of 24±2hrs No damage Table 1	Att - ΔAtt	Record values - ±0.05 ±0.5		- - dB or % (2)
04	Climatic sequence	Para 13.2.9 of Generic specification Dry heat: para 13.2.9.1 of Generic specification Cold heat: para 13.2.9.3 of Generic specification	Attenuation drift Attenuation drift Final measurement Visual Examination Attenuation drift	At +125°C, Freq: 10GHz – 20GHz – 30GHz – 40GHz - 50GHz At -55°C, Freq: 10GHz – 20GHz – 30GHz – 40GHz - 50GHz After recovery time between 1 hr and 24 hrs No damage Table 1	ΔAtt ΔAtt - ΔAtt	7.10 ⁻⁴ (3) 7.10 ⁻⁴ (3)	dB/dB/°C dB/dB/°C	
05	Coupling proof torque	Para 13.2.10	Interface dimensions	Para 13.2.11	-	Figure of para 13.2.11		-
06	Mating and unmating forces	Para 13.2.11	Torque	Para 13.2.11	-	-	24	N.cm
07	Connector Repeatability	Para 6 of this specification	Attenuation drift	Table 1	ΔAtt	±0.05 ±0.5		dB or % (2)
08	Operating Life	Para 13.2.12 and table 3 and 4 of this specification	Initial measurements Attenuation Final measurement Visual Examination Attenuation drift	Table 1 No damage Table 1	Att - ΔAtt	Record values - ±0.10 ±1		- - dB or % (2)
09	RF leakage	Para 13.2.13 of Generic specification	RF leakage	Para 13.2.13 DC to 50GHz	E	-	-85	D B
10	Peak power	Para 13.2.14 of Generic specification and table 2 of this specification	Final measurement Attenuation	Table 1	Att	Table 1		
11	Permanence of marking	Para 13.2.16 of Generic specification	Final measurement Visual Examination	No corrosion or obliteration of marking	-	-		-

Notes:

- (1) The tests in this table refer to either para 11 and 12 of Generic specification and shall be used as applicable
- (2) Whichever is greater
- (3) or ±0.1dB whichever is greater.